

morphyrichards®

2 & 4 slice essentials toaster



Please read and keep these instructions

UK
 Helpline 0870 060 2614
 Replacement parts 0870 167 6645

Ireland
 1800 409119

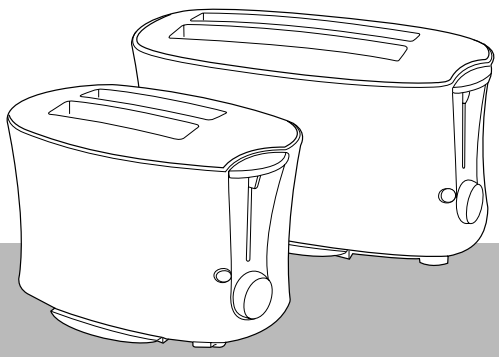

getting the best from your new toaster...

• **Safety first**

Do not touch metal top of the toaster during or after use as it gets very hot.

• **Empty crumb tray regularly**

To clean away any crumbs that accumulate after use.

• **In order to achieve uniform browning**

Wait a minimum of 30 seconds between each toasting, so that the control can automatically set.



www.morphyrichards.co.uk

Important safety instructions

The use of any electrical appliance requires the following common sense safety rules.

Primarily there is danger of injury or death and secondly the danger of damage to the appliance. These are indicated in the text by the following two conventions:

WARNING: Danger to the person!

IMPORTANT: Damage to the appliance! In addition we offer the following safety advice.

Location

- Always locate your toaster away from the edge of the worktop.
- Ensure that the toaster is used on a firm, flat, heat resistant surface.
- Ensure that sufficient space is left above and around all sides of your toaster to allow air to circulate.
- **IMPORTANT:** Do not use too close to curtains, draperies, walls, cupboards and other flammable materials.
- **Do not use underneath cupboards.**
- Do not use outdoors.

Mains lead

- The mains lead should reach from the socket to the toaster without straining the connections. Reduce the length of the excess lead by using the cord storage facility.
- Do not let the mains lead hang over the edge of the worktop where a child could reach it.
- Do not let the lead run across an open space e.g. between a low socket and table.
- Do not let the lead run across a cooker or hot area which might damage the cable.

Personal safety

- Do watch your toaster during use.
- **WARNING: Do not touch the top of the toaster or other hot parts during or after use, use handles or knobs.**
- **WARNING: Do not insert oversize foods, metal, foil packages or utensils into the toaster.**
- **WARNING: Do not attempt to dislodge food when the toaster is plugged in and never insert cooking utensils into the slots.**
- **IMPORTANT: Do not place bread or other items on top of the slots as this may damage the toaster and creates a fire hazard.**

Children

- Never allow a child to operate this appliance
- Children are vulnerable in the kitchen particularly when unsupervised and if appliances are being used or cooking is being carried out.
- Teach children to be aware of dangers in kitchen, warn them of the dangers of reaching up to areas where they cannot see properly or should not be reaching.

Other safety considerations

- Do not operate with a damaged cord or plug or after the appliance malfunctions or has been damaged in any manner.
- Do not attempt repairs - the appliance contains no user-serviceable parts. Call our helpline for advice.
- Do not use accessories not recommended by the manufacturer.
- Do not place on or near a hot gas electric burner or in a heated oven.
- Do not immerse cord, plug or toaster in water or other liquid.
- Only use for intended purpose.
- Unplug from outlet when not in use and when cleaning.
- Do not move the appliance whilst hot.

Electrical requirements

Check that the voltage on the rating plate of your appliance corresponds with your house electricity supply which must be A.C. (Alternating current).

If the socket outlets in your home are not suitable for the plug supplied with this appliance the plug should be removed and the appropriate one fitted.

WARNING : The plug removed from the mains lead, if severed, must be destroyed as a plug with a bared flexible cord is hazardous if engaged into a live socket outlet.

Should the fuse in the 13 amp plug require changing a 13 amp BS1362 fuse must be fitted.

WARNING: THIS APPLIANCE MUST BE EARTHED.

Features

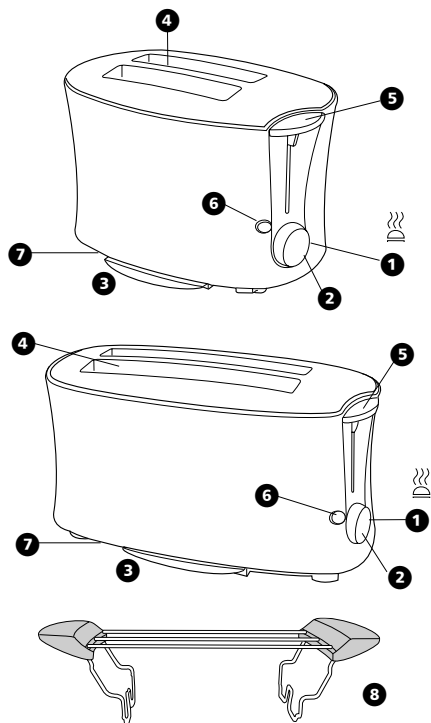

- ❶ Bun warmer setting (on browning control)
- ❷ Electronic variable browning control
- ❸ Removable crumb tray
- ❹ Bread slots
- ❺ Bread carriage lever with high lift feature
- ❻ Cancel button ○
- ❼ Cord storage
- ❽ Bun warmer

Before first use

- Before using the toaster for the first time operate the toaster without bread. *Note: the bread carriage lever ❺ will not stay down unless the toaster is plugged in and the wall switch is on.* Ventilate the room during this period.
- As with all new electric heating elements, your toaster emits a 'new' smell when it is first switched on. This is quite normal and not a cause for concern.

Instructions for use

- 1 Select the desired level of browning on the browning control ❷ marked 1 to 8. The setting required will vary according to the moisture content and thickness of the bread. For best results ensure that the bread slices are of even thickness, freshness and size. Remember that stale bread toasts more rapidly than fresh and thin bread toasts quicker than thick. See additional points for more information.
- 2 After selecting the desired level, place your bread in the slots ❹ and depress the bread carriage lever ❺ downwards until it locks.

- 3** After the set time has been reached the bread will pop up automatically ready for removal from the slots. The bread carriage lever will have returned to its upper position and the heating element will have switched off.
- If the bread in your toaster becomes jammed disconnect your toaster at the socket, allow it to cool, then remove the bread.
 - When not in use, switch your toaster off at the mains and remove the plug from the socket. **DO NOT WRAP THE CABLE AROUND THE MAIN BODY OF THE APPLIANCE DURING OR AFTER USE.**

Using the cancel button

If you wish to interrupt the toasting process, press the cancel button **6**.

Using the bun warmer

Unfold the bun rack and place it on top of the toaster ensuring it is securely in place. Place the buns or other items onto the bun warmer. Set the browning control to the bun warmer position **1**. Depress the bread carriage lever until it holds down. Wait for the toaster to switch off automatically or press the cancel button to switch the toaster off before removing the buns.

WARNING: Take care not to touch the metal of the bun warmer as it will be hot.

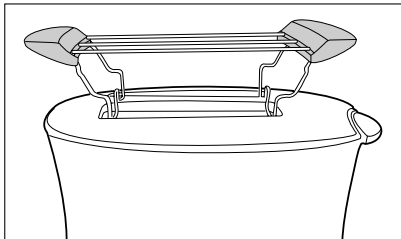

Do not put more than two buns on the bun warmer at any one time.

Additional points

- In order to achieve uniform browning, we recommend you wait a minimum of 30 seconds between each toasting, so that the control can be automatically reset.
- If toasting one slice only, you may need to adjust the browning control to a slightly lower setting.
- Note you will also notice a slight variation in toast colour on one side of a single slice.
- Stale bread toasts more rapidly than fresh bread. Therefore, the browning control should be set at a lower setting than usual.
- All sorts of bread can be used as well as teacakes, small rolls etc. Slices should not however be so thick as to cause burning or jamming within the bread slots.
- When toasting 2 or more slices it is recommended they are of equal size and freshness.
- Allow the toaster to cool fully before putting away.

Cleaning and maintenance

- 1 After use and before cleaning, switch off at the mains, remove the plug from the wall socket and wait for the toaster to cool.
 - 2 Wipe the outside of the toaster with a damp cloth only and dry with another cloth or tissue.
- NEVER use metal polish or coarse scouring agents and never immerse your toaster in any sort of liquid.
 - NEVER use any pointed or sharp articles for cleaning the inside, otherwise the heating element will be damaged.
 - NEVER use a brush or push your fingers or metal objects down the slots.

Crumb tray

WARNING: Crumbs will accumulate in the crumb tray and could catch fire if not emptied periodically. When the toaster has cooled down completely, tap the sides of the case lightly to dislodge any crumbs lodged in the toasting chamber and pull out the crumb tray **3**. Empty the tray and replace it.

Never operate the toaster without the crumb tray fitted.

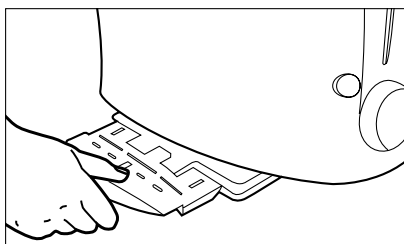

Helpline

If you have any difficulty with your appliance, do not hesitate to call us.

We are more likely to be able to help than the store from where you bought it.

Please have the following information ready to enable our staff to deal with your query quickly.

- Name of the product
- Model number as shown on the underside of the appliance.



Your two year guarantee

It is important to retain the retailers receipt as proof of purchase. Staple your receipt to this back cover for future reference.

Please quote the following information if the product develops a fault. These numbers can be found on the base of the product.

Model no. Serial no.

All Morphy Richards products are individually tested before leaving the factory. In the unlikely event of any appliance proving to be faulty within 28 days of purchase, it should be returned to the place of purchase for it to be replaced.

If the fault develops after 28 days and within 24 months of original purchase, you should contact the Helpline number quoting Model number and Serial number on the product, or write to Morphy Richards at the address shown.

You will be asked to return the product (in secure, adequate packaging) to the address below along with a copy of proof of purchase.

Subject to the exclusions set out below (see Exclusions) the faulty appliance will then be repaired or replaced and dispatched usually within 7 working days of receipt.

If for any reason this item is replaced during the 2 year guarantee period, the guarantee on the new item will be calculated from original purchase date. Therefore it is vital to retain your original till receipt or invoice to indicate the date of initial purchase.

Morphy Richards products are intended for household use only.

Morphy Richards has a policy of continuous improvement in product quality and design. The company, therefore reserves the right to change the specification of its models at any time.

To qualify for the 2 year guarantee the appliance must have been used according to the manufacturers instructions. For example kettles should have been regularly descaled.

EXCLUSIONS

Morphy Richards shall not be liable to replace or repair the goods under the terms of the guarantee where:

- 1 The fault has been caused or is attributable to accidental use, misuse, negligent use or used contrary to the manufacturers recommendations or where the fault has been caused by power surges or damage caused in transit.
- 2 The appliance has been used on a voltage supply other than that stamped on the products.
- 3 Repairs have been attempted by persons other than our service staff (or authorised dealer).
- 4 Where the appliance has been used for hire purposes or non domestic use.
- 5 Morphy Richards are not liable to carry out any type of servicing work, under the guarantee.
- 6 Plastic filters for all Morphy Richards kettles and coffee makers are not covered by the guarantee.

This guarantee does not confer any rights other than those expressly set out above and does not cover any claims for consequential loss or damage. This guarantee is offered as an additional benefit and does not affect your statutory rights as a consumer.

- This guarantee is valid in the UK and Ireland only.

morphy richards®

Registered address
The After Sales Division
Morphy Richards Ltd, Mexborough
South Yorkshire, England, S64 8AJ

Helpline (office hours)
UK **0870 060 2614**
Republic of Ireland **1800 409119**

TT44150M UK Rev 1